

ON-ROAD AC INDUCTION MOTOR CONTROLLER



CURTIS

MODEL 1238R



DESCRIPTION

The Curtis Model 1238R provides energy efficient control of AC induction motors performing on-vehicle traction drive duties. It offers vehicle developers a highly cost-effective combination of power, performance and functionality.

APPLICATION

Designed for use as a traction controller for on-road electric and hybrid passenger vehicles using 72–96V system voltages, and other similar applications with low or medium duty cycles.

Patents Pending

Only Curtis AC can offer:

- **Curtis VCL—Vehicle Control Language** is an easy to use programming language that allows vehicle developers to write powerful logic functions and create a 'virtual system controller'. Curtis offers customers VCL development tools and training. Curtis also provides a VCL service where Curtis engineers will work with the OEM to create any custom VCL code required.
- **Indirect Field Orientation (IFO) vector control** algorithm generates the maximum possible torque and efficiency across the entire speed range. Advanced Curtis IFO vector control provides superb drive 'feel', improved speed regulation and increased gradeability.
- **Curtis Auto-Tune** function enables quick and easy characterization of the AC motor without having to remove it from the vehicle. Curtis AC controllers are fully compatible with any brand of AC motor.
- **Dual-Drive functionality** is standard, allowing correct control of applications featuring twin traction motors. This function ensures smooth and safe operation, minimal tire wear and correct load sharing between the traction motors at all times.
- **Configurable CANbus** connection allows communication with other CANbus enabled devices. Model 1238R is CANopen compatible and can be further customized and configured using VCL.
- **Integrated System Controller** - More than just a motor controller, it is also powerful system controller. It features a comprehensive allocation of multi-function I/O pins for use as analog inputs, digital inputs, contactor coil drivers and proportional valve drivers. In addition to this local I/O, this controller can use VCL to map and configure the remote I/O available on other CANbus devices, send messages to CAN displays and thus control and monitor the entire system.

FEATURES

Advanced functionality, compact power

- High frequency, silent operation across the 0–300Hz stator frequency range.
- Two models of 1238R are available, offering outputs of 550A or 650A for a 72–96V nominal system voltage. This is a 72–96V nominal system voltage. This is a true 2 minute RMS rating, not a short duration 'boost' rating.

MODEL 1238R

FEATURES *continued*

- Powerful operating system allows parallel processing of vehicle control tasks, motor control tasks and user configurable programmable logic.
- Advanced Pulse Width Modulation techniques produce low motor harmonics, low torque ripple and minimized heating losses, resulting in high efficiency.

Unmatched Flexibility

- Programmable for either traction or pump applications.
- Field upgradeable software.
- Integrated Battery state-of-charge algorithm and hour meter.
- Multi-Mode™ provides user-selectable vehicle operating profiles.
- Comprehensive programming options and VCL allow other applications to be easily supported.
- Curtis hand-held or PC Windows programming tools provide easy programming and powerful system diagnostic tools.
- Integrated status LED provides instant diagnostic indication

Robust Safety and Reliability

- Insulated Metal Substrate power base provides superior heat transfer for increased reliability.
- Fail-Safe power component design.
- Redundant hardware watchdog timers.
- Reverse polarity protection on battery connections.
- Short circuit protection on all output drivers.
- Thermal cutback, warning, and automatic shutdown provide protection to motor and controller.
- Rugged sealed housing and connectors meet IP65 environmental sealing standards for use in harsh environments.

Meets or complies with relevant US and International Regulations

EMC: Designed to the requirements of EN12895

Safety: Designed to the requirements of EN1175

IP65 Rated per IEC 529

Regulatory compliance of the complete vehicle system with the controller installed is the responsibility of the vehicle OEM.

MODEL CHART

Model	Battery Voltage V	2 Min RMS Current Rating Arms (A)	2 Min RMS Power Rating (kVA)
1238R-75XX	72-96	550	62.3
1238R-76XX	72-96	650	73.6

SYSTEM ACCESSORIES



The Curtis enGage™ IV is a fully customizable, microprocessor based CANbus Instrument that can be programmed to monitor, display and control numerous vehicle functions in a single integrated package.



The Curtis model 1352 CANbus I/O expansion module features 9 I/O pins, including 6 proportional valve drivers. This module can be used to further expand the I/O capability of Curtis AC motor controllers using VCL.



The Curtis Model 1311 Handheld Programmer is ideal for setting parameters and performing diagnostic functions.

Contact Curtis to obtain the VCL Vehicle Control Language compiler and development tools.

MODEL 1238R

CONNECTOR WIRING

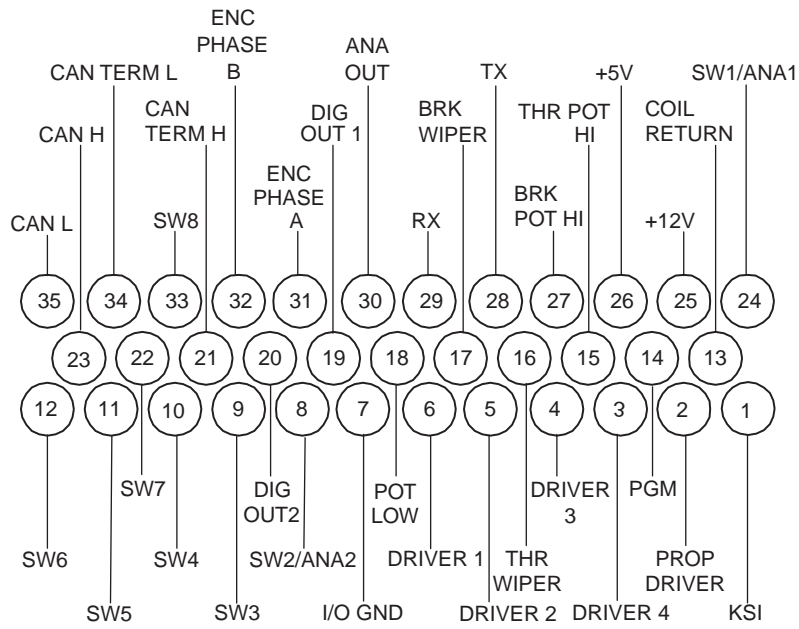

DIMENSIONS mm

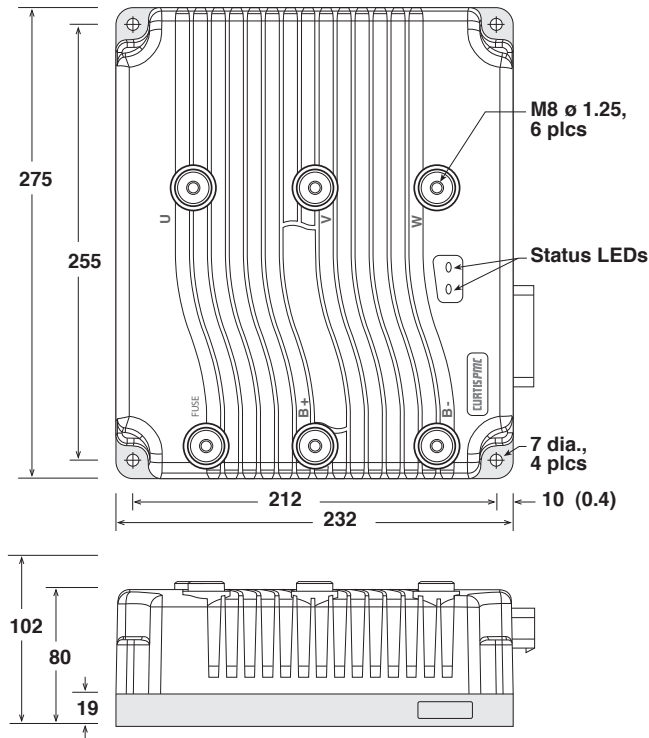

MODEL 1238R

TYPICAL WIRING

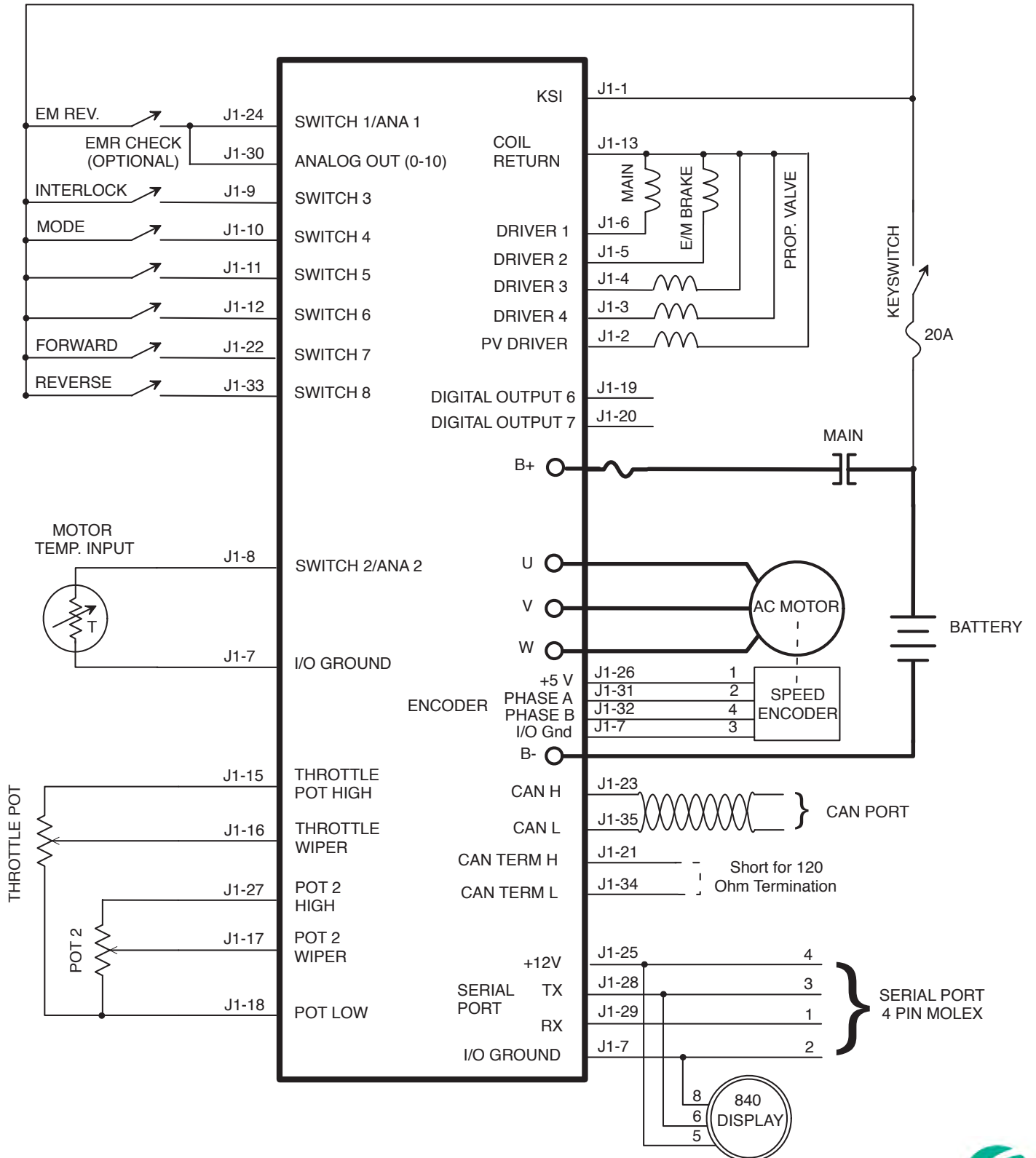

WARRANTY Two year limited warranty from time of delivery.



is a trademark of Curtis Instruments, Inc.

Specifications subject to change without notice

©2010 Curtis Instruments, Inc.

50175 REV D 12/10

