

# PFC2000+



## Description

- Advanced high frequency switching design with 92% typical efficiency
- Fully sealed enclosure providing improved reliability in demanding environments
- > 0.98 Power Factor minimizes utility surcharges and maximizes use of AC power
- Approved battery charge algorithms for ideal charging (default I1, I2, U, I3a)
- Memory to store 10 unique algorithms, and tools to load new algorithms in the field
- The internal CPU employs advanced charging management algorithm

## Technical Features

### DC Output

Model	36XX	48XX	60XX	72XX	84XX	96XX
DC Output Voltage - nominal	36V	48V	60V	72V	84V	96V
DC Output Voltage - maximum	51V	68V	85V	102V	119V	136V
DC Output Current - 230vac	40A	30A	26A	22A	19A	15A
DC Output Current - 115vac	35A	27A	24A	20A	17A	13A
Model	120XX	144 XX	156XX	168XX	288XX	
DC Output Voltage - nominal	120V	144V	156V	168V	288V	
DC Output Voltage - maximum	170V	204V	221V	238V	408V	
DC Output Current - 230vac	13A	11A	10A	9A	5.5A	
DC Output Current - 115vac	12A	10A	9A	8A	5A	
Battery Type	Specific to selected algorithm					
Reverse Polarity	Electronic protection – auto-reset					
Short Circuit	Output closed automatically					

### AC Input

AC Input Voltage - range	90 - 260VAC
AC Input Voltage - nominal	120 VAC / 230 VAC
AC Input Frequency	45 - 65 Hz
AC Input Current - maximum	15A
Current – nominal	14 A rms @ 120 VAC / 9.5 A rms @ 230 VAC
AC Power Factor - nominal	> 0.98

### Mechanical

Dimensions	352mm×195mm×139mm
Weight	< 7 kg Standard output cord
Environmental Enclosure	IP46
Operating Temperature	-30°C to +50°C (-86°F to 122°F)
Storage Temperature	-40°C to +85°C (-104°F to 185°F)

### LED Indicator

Red-Green flash (one second interval)	Battery Disconnected
Red flash (three seconds interval)	Repair Battery
Red flash (one second interval)	<80% Charge Indicator
Yellow flash (one second interval)	>80% Charge Indicator
Green flash (one second interval)	100% Charge Indicator

### Protection Features

1. Thermal Self-Protection: When the internal temperature of the charger exceeds 80°C, the charging current will reduce automatically. If exceeds 85°C, the charger will shutdown protectively, there is no current output in this case. When the internal temperature drops to 80°C, it will resume charging automatically.
2. Short-circuit Protection: When the charger encounters unexpected short circuit across the output, charging will automatically stop. By cutting AC power for 10 seconds, the charger can be re-set and will start normally(with the output circuit corrected)
3. High and Low Voltage Protection: When the input AC Voltage is higher or lower than the rated input voltage range, the charger will shutdown protectively, but resume working after the voltage is normal again.

### Inter-lock Function

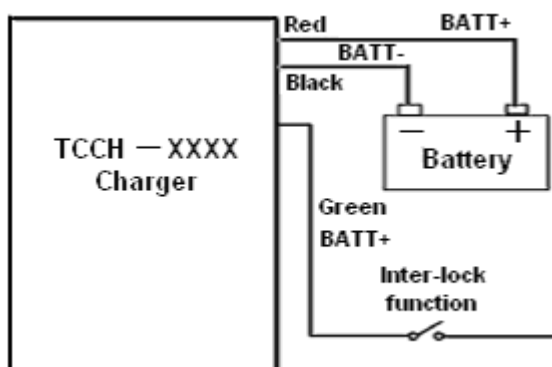

Connect to coil of main contactor, DC/DC converter or controller enable wires.

Normally battery voltage +, but OV while charging.

Note: The current through green Interlock wire must not exceed 2A.

### Choice of Charging Curve (curve 1~10)

1.The LED will flash red several times when AC is first connected, then the LED will flash green once. The number of red flashes denotes the present curve. E.g. If the red flashes three times, it means the present curve is curve 3.

2.To choose another curve, please cut off the power supply first, then unpeel the label, pressing the button while connecting the power. If you want to choose curve 3, release the button after the 3<sup>rd</sup> LED Flash. Now the selected curve (e.g. curve 3) will be recorded in memory. If you want the charger to work with the selected curve (e.g. curve 3), cut off the power and reconnect it.

### Alarms

	LED Flashing Sequence ( One Cycle )	Indication
1	R G _ _ _ _ _	Wrong Battery
2	R G R _ _ _ _	Overcharged
3	R G R G _ _ _ _	The temperature of battery is too high
4	R G R G R _ _ _	Incorrect AC Input Voltage
5	R G R G R G _ _	Internal thermal sensor of charger fault
6	R G R G R G R _	Communication interface fault
7	G R _ _ _ _ _	Charger temperature is too high
8	G R G _ _ _ _	The charger relay is in fault ; Repair
9	G R G R _ _ _ _	Charger is in fault; Repair

### Note:

1. R—red G—green

2. “\_” denotes one second stop

3.Above LED flashing sequence is just one cycle, the LED will flash repeatedly when in fault

### Installation & Safety Instructions

Our charger has been designed for safety and reliability. It is important to observe the following precautions and installation instructions in order to avoid damage to persons and to the battery charger. For further reference retain the instruction.

1. Attach the charger to a stable surface with the holes on the mounting tabs. In case of installation on a vehicle, it is advisable to use anti-vibration supports.

2. Preferably the charger should be installed in the vertical position with radiator fins vertical. A space of 10cm above ground should be open to ensure airflow. Never install in the vertical position with fins facing down. Refer to drawing below :

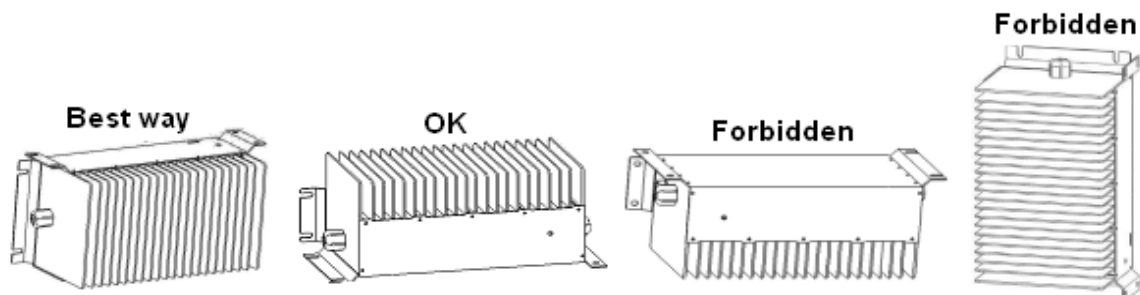

3. Ensure all heat-dissipating parts are not obstructed to avoid overheating. Do not put the battery charger near any heat sources. Make sure that free space around the charger is enough to provide adequate ventilation & easy cable socket access.
4. For safety and electromagnetic compatibility the battery charger has a 3-prong plug that will only plug into a properly grounded outlet.
5. To avoid damaging the power cord, do not put anything on it or place it where it will be walked on. If the cord becomes damaged or frayed, replace it immediately.
6. If you are using an extension cord or power strip, make sure that the total of the amperes required by all the equipment on the extension is less than the extension's rating.
7. Verify that the selected charging curve is right for the type of battery to be charged.
8. In order to avoid voltage drop, the output cables must be as short as possible, and the wire gauge must be adequate for the output current.
9. Do not try to service the charger yourself. Opening the cover may expose you to shock or other hazards.
10. If the charger does not work correctly or if it has been damaged, unplugged it immediately from the supply socket, from the battery and contact a retailer.
11. The thermal compensation probe for the battery voltage must be placed in the area of the highest battery temperature, such as between 2 batteries near the center of the pack.

**Attentions**

To reduce the risk of electric shock, do not remove cover. Refer servicing to qualified personnel. Disconnect the mains supply before connecting or disconnecting the links to the battery. Read the instruction manual carefully before use. Verify that the selected charge curve is suitable for the type of battery you have to charge.

**Mechanical Dimensions**

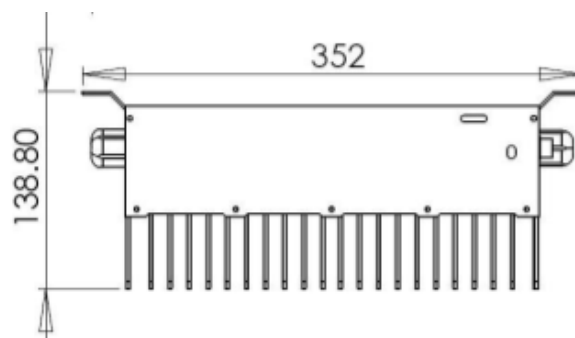

All dimensions are expressed in mm